



PT Multi Trading Pratama – Company Snapshot



A privately owned Indonesian company incorporated in Makassar, South Sulawesi, Indonesia in September 2005



One of the two market leaders in Indonesia growing bitumen industry of close to 2.0 million tons p.a



13 terminals strategically located at four major islands in Indonesia, 450 tank trucks and 9 vessels/barges





MARKET SHARE

✓ Close to 50 % growth of market share for last 5 years

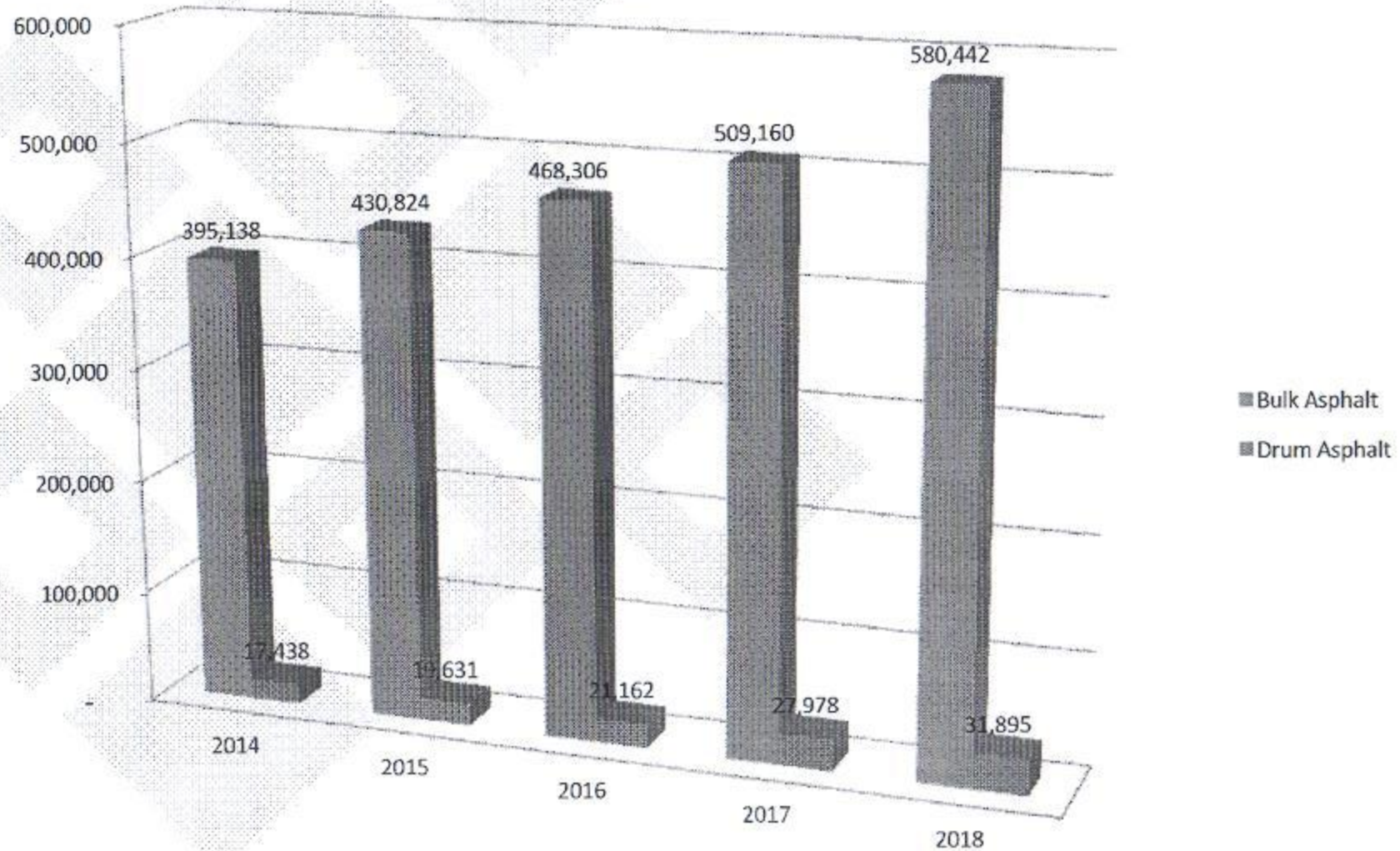



Build bitumen refinery in Barru



- Ensure sustainability of the company
- Refinery capacity of 2 x 30,000 mbpd



*Thank
You*



PT Multi Trading Pratama

Jl. Lure No. 4/8

Makassar Sulawesi Selatan

Sulawesi Selatan 90134,

Indonesia. <http://www.multitradingpratama.co.id/>

e-mail : marketing@multitradingpratama.com



Refinery – Schematic Flow Diagram

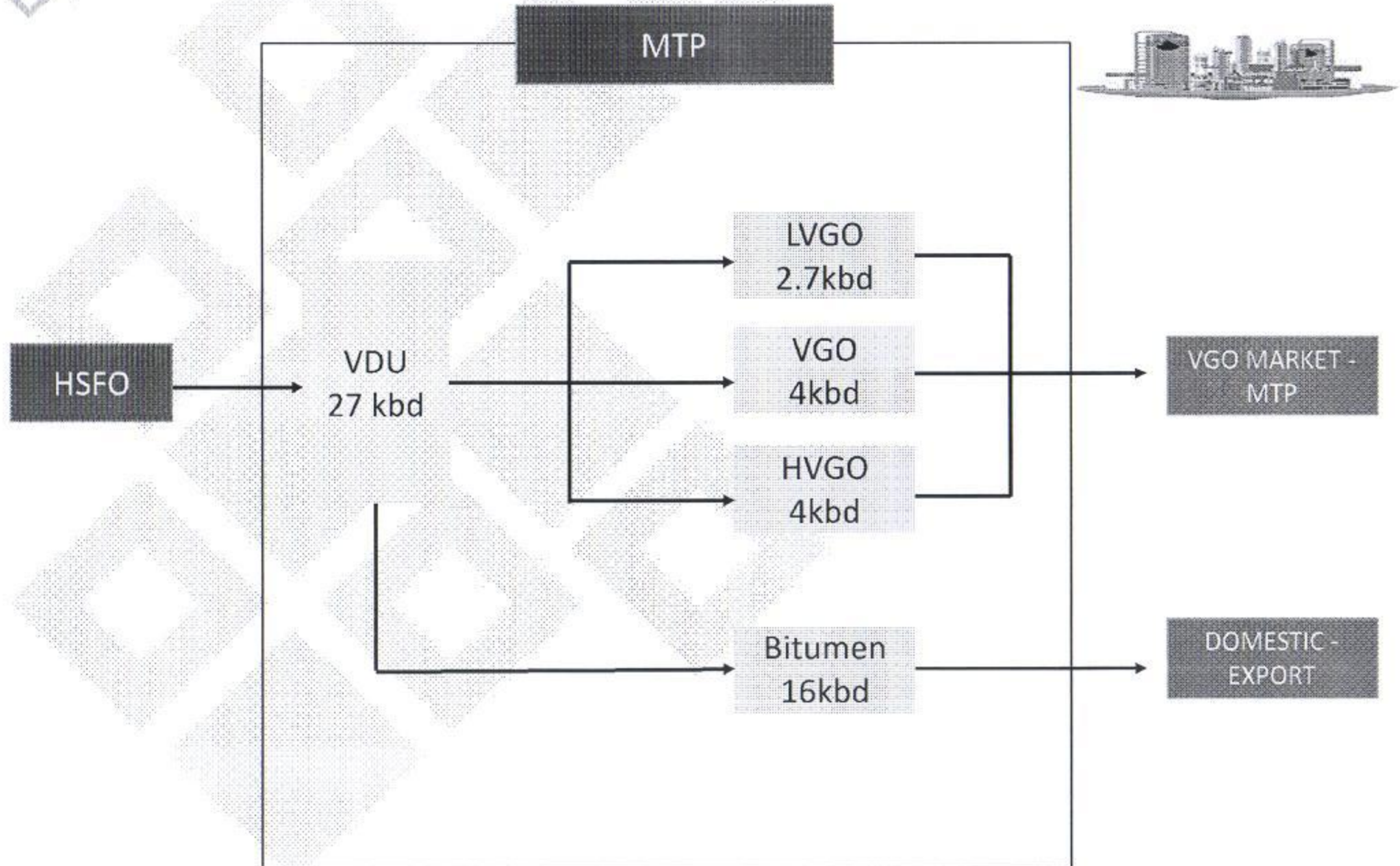

Indonesia domestic bitumen requirements is 2.0 million tons p.a. However, domestic production will cease by 2020

Plaju

Capacity :118 kbpd
NCI:3.10
Unit: CDU, HVU, FCCU
Polypropylene PTA

Dumai

Capacity :170 kbpd
NCI:7.50
Unit: CDU, HDU,
HCK, D, Coker, Plaformer

Balikpapan

Capacity :260 kbpd
NCI : 3.27
Unit: CDU, HVU, HCK,
Platformer, Wax Plant

Kassim

Capacity :10 kbpd
Unit: CDU, NHDT, PLF

Balongan

Capacity :125 kbpd
NCI: 11.90
Unit: CDU, ARHDM, RCC
Complex, Polypropylene Rec,
LPG Plang

Cilacap

Capacity :348 kbpd
NCI: 3.98
Unit: FOC I & FOC II
Lube oil Plan I,II,& III
Asphalt Plant
Paraxylene Plant

TPPI Tuban Condensate splitter

Capacity :100 kbpd
Unit: Condensate splitter
Paraxylene Plant

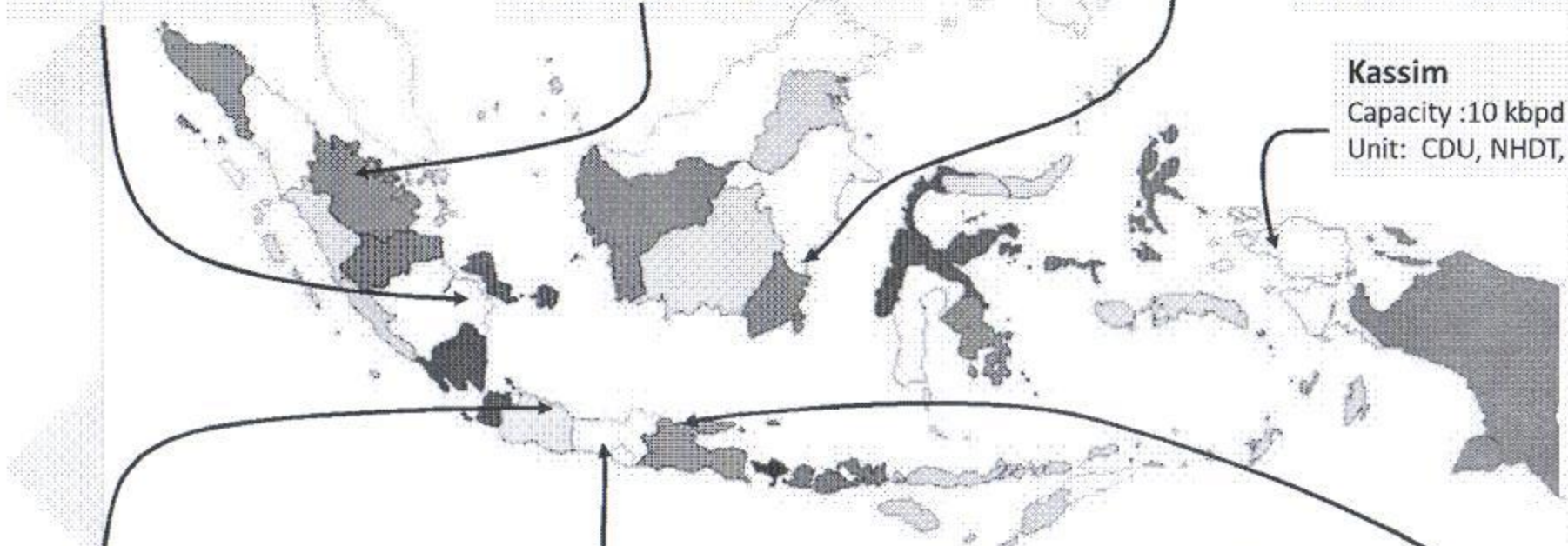



Build Bitumen and Gasoil Terminal in Kendari

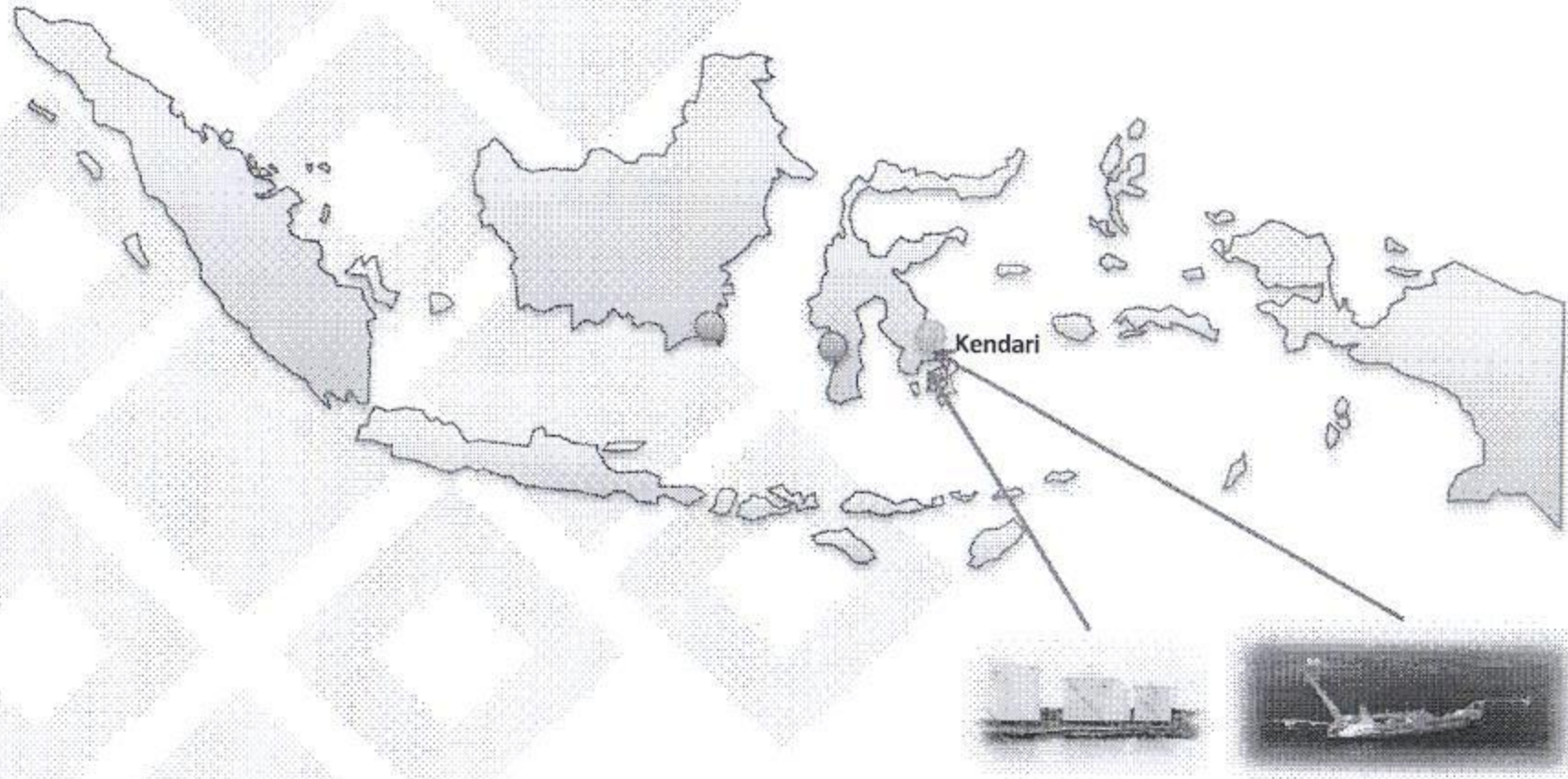



Development of Palembang Terminal

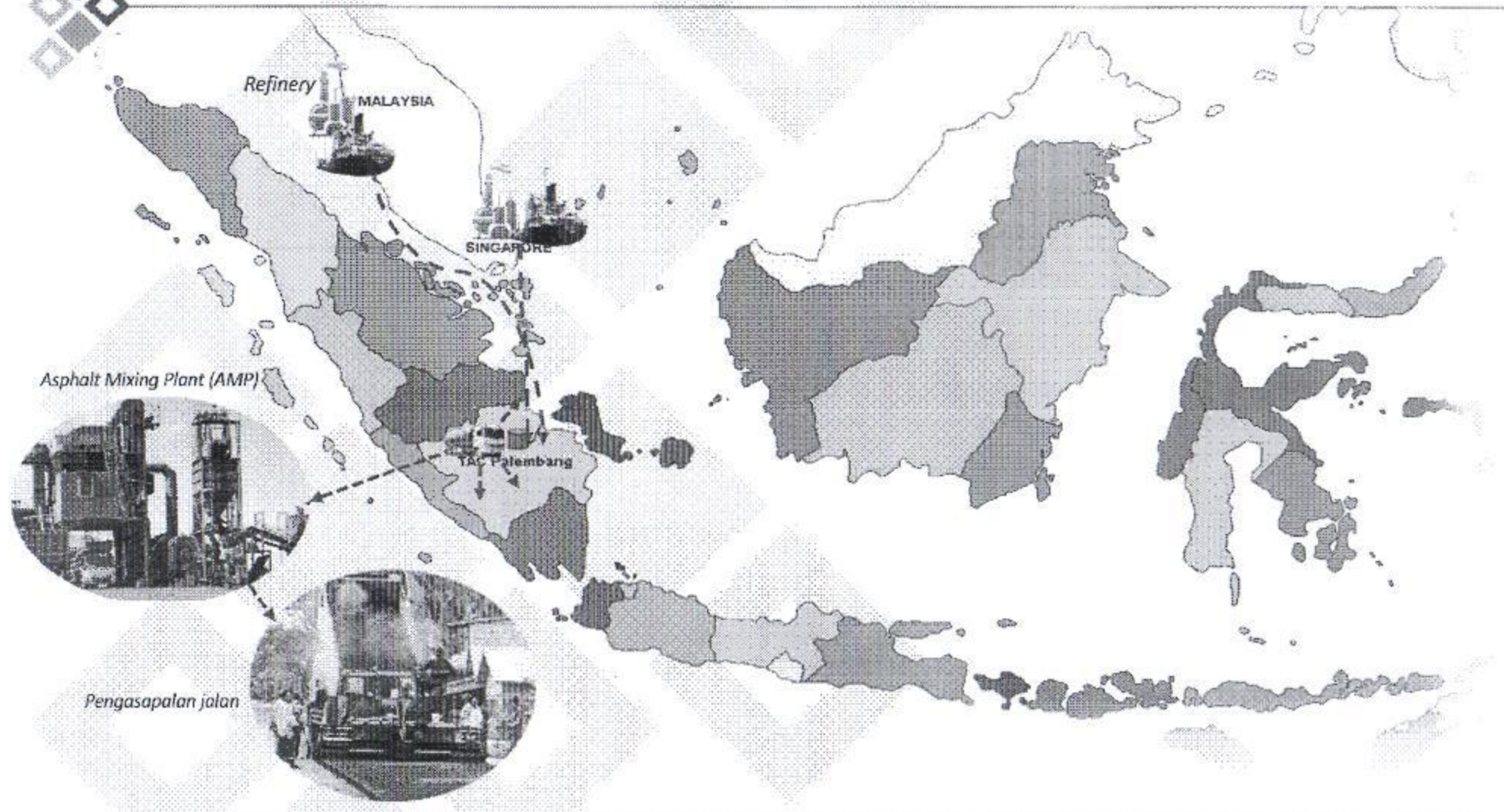

Logistic Facilities	Total / Capacity	Location
Storage Tank Terminal	1 Terminal Aspal Curah	Jl. Sabar Jaya No. 12, Desa Perajin – Mariana Kec / Kab. Banyuasin, Palembang – Sumsel
Ports	1 port / 5.000 DWT	
Storage tank	5000 MT	
Self-propelled vessels	9 Units	
Warehouses	1 unit	
Trucks	50 units	



Refinery in Barru – Layout Plan

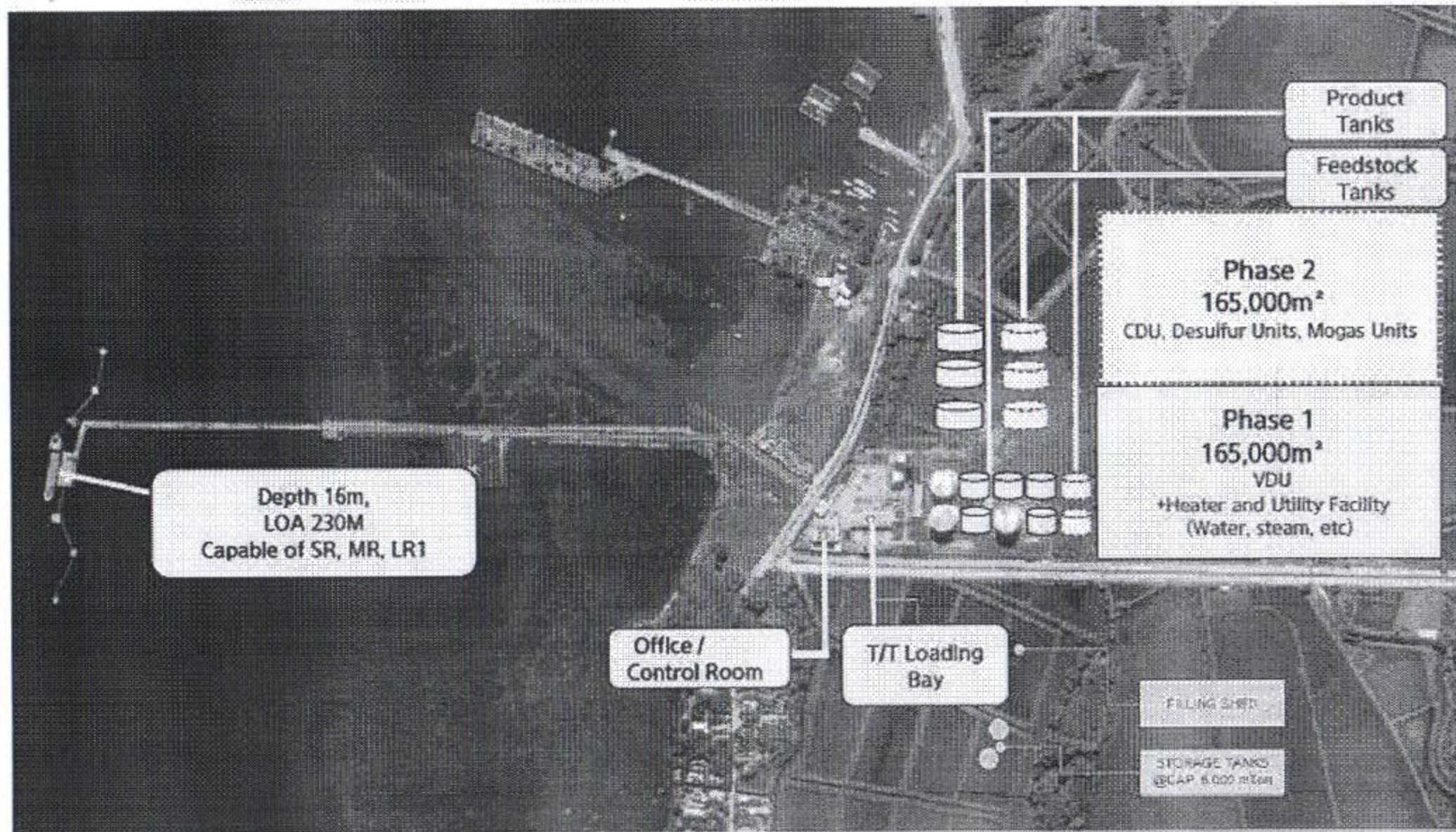



Board of Director

PT. MULTI TRADING PRATAMA GROUP

President Director
Yusuf Tyos

Advisor
Ahmad Idris Basirun
Djoko Ary Wijanto

Finance director
Meikewati Bunadi

Operations director
Abdul Gaffar

Marketing director
Alfred Alrens Bunadi



LOGISTIC FACILITIES

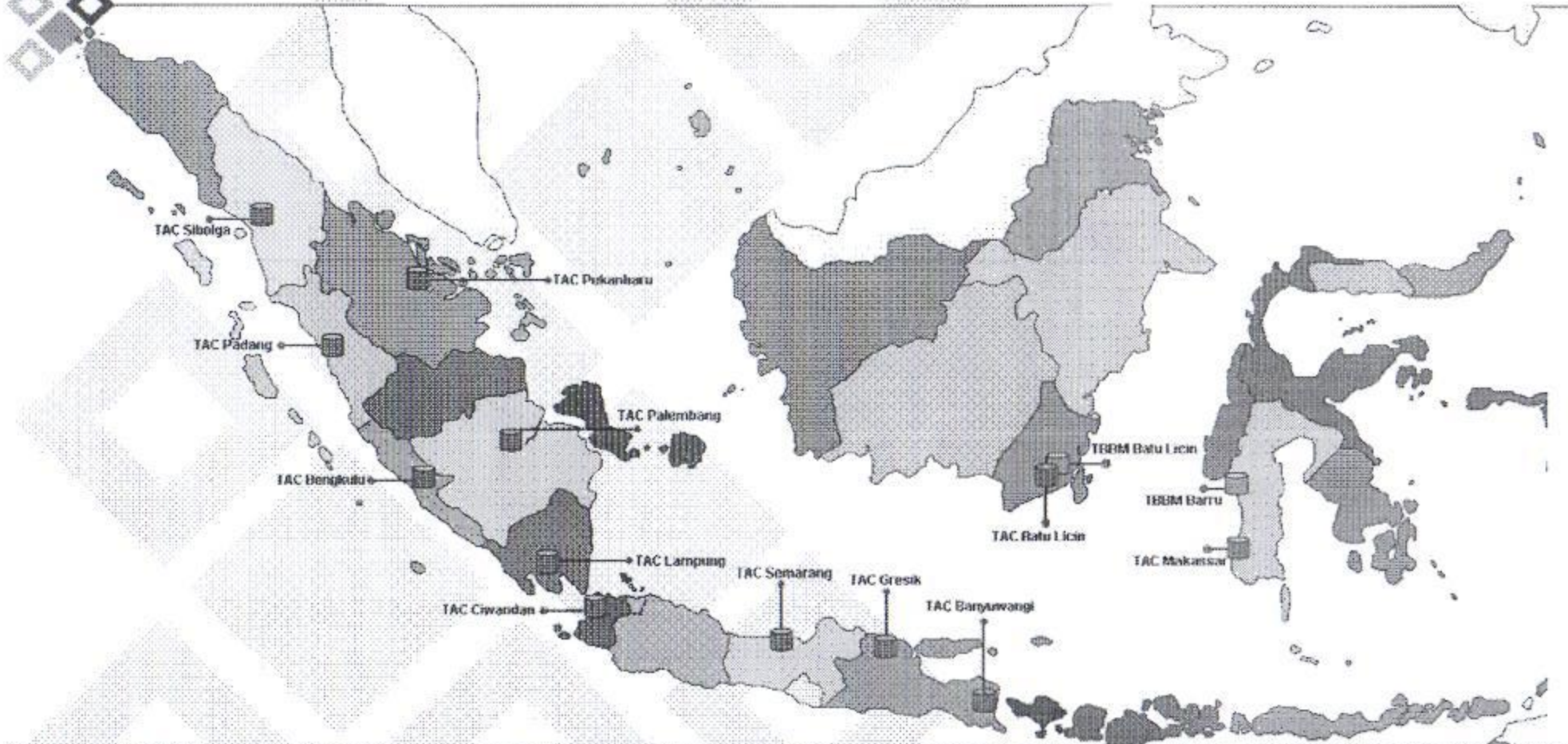

Logistic Facilities	Total / Capacity	Terminal	
		Owned	Lease
Storage Tank Terminal	13 Terminal	Barru : Fuel	Makassar : Bitumen Lampung : Bitumen
Ports	13 ports	Palembang: Bitumen	Banyuwangi: Bitumen Bengkulu : Bitumen
Storage tank	70,800 MT	Batu Licin : Fuel/Bitumen.	Gresik : Bitumen Padang : Bitumen Semarang : Bitumen Pekanbaru : Bitumen Ciwandan : Bitumen Sibolga : Bitumen
Self-propelled oil barges & vessels	9 Units	✓	
Trucks	450 units	✓	



NON FUEL RETAIL

- ❖ increasing the competitiveness of retail stations by completing the rest area with additional modern services such as cafes
- ❖ Drinking coffee has become a deeply rooted culture in Indonesia, coffee is not just just a body warming drink, but has become a means of socializing
- ❖ We have option to open outlet in a gas station, or as a stand-alone coffee shop and may open at any strategic locations such as malls, office buildings, schools, condominium etc.
- ❖ As a private company in Indonesia that continues to grow, especially in the oil and gas sector, we have now planned to develop the Fuel Oil retail business by establishing approximately 20 gas stations equipped with rest areas including the Café inside.
- ❖ The growth of upper middle class customers is certainly a market share for the Café which will be placed both at the gas station rest area and stand alone.



multi trading pratama group
Global Integrated Downstream Petroleum Company



PT. Multi Trading Pratama Presentation

2019



ISSUES & CHALLENGES

- Imports all products. Mainly, from Singapore
- Requires funds for growth and expansion

GROWTH STRATEGIES

- Bitumen Refinery in Barru
- Retail Fuel Stations in South Sulawesi
- Storage Hub in Barru
- Development of Palembang and Kendari Terminal

2. PENAMBAHAN STORAGE HSD & MOGAS

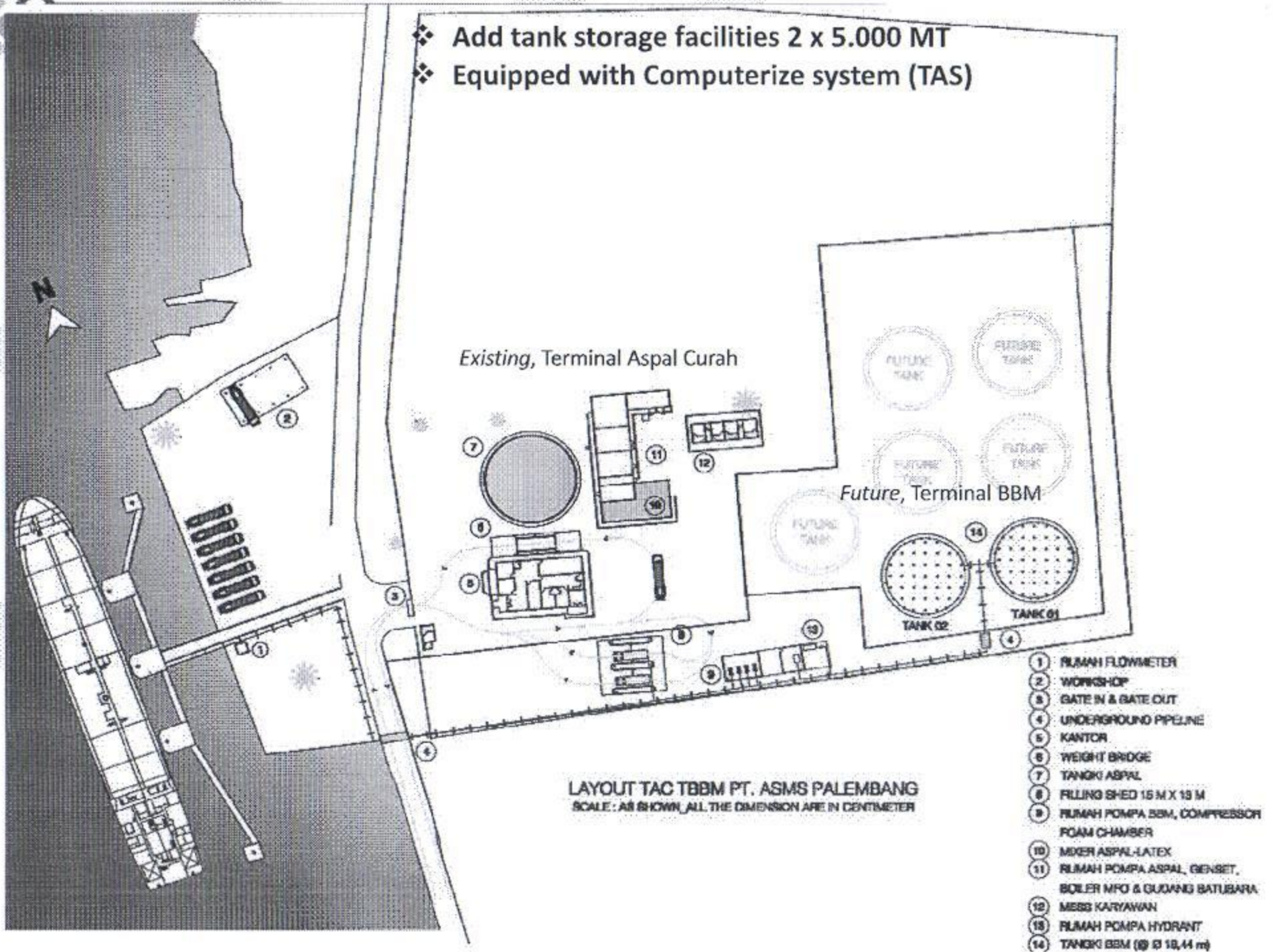



Retail Fuel Stations in South Sulawesi



- Diversify from over reliance on bitumen business and maximize assets utilization
- Build 20 retail fuel stations in South Sulawesi in 5 years
- Presently, owned 2 retail station sites in South Sulawesi



Australia provides an opportunity for MTP to serve one million p.a. bitumen requirements

